



**Facility Study  
For  
Generation Interconnection  
Request  
GEN-2012-016**

***SPP Generation  
Interconnection Studies***

***(#GEN-2012-016)***

**August 2013**

---

## Revision History

---

Date	Author	Change Description
08/25/2013	SPP	Facility Study Report Issued

## **Summary**

Oklahoma Gas and Electric (OKGE) and Western Farmers Electric Cooperative (WFEC) performed a detailed Facility Study at the request of Southwest Power Pool (SPP) for Generation Interconnection request GEN-2012-016 (312MW/ Combustion Turbine) located near Mooreland, Oklahoma. The originally proposed in-service date for GEN-2012-016 is March 1, 2017. The request for interconnection was placed with SPP in accordance with SPP's Open Access Transmission Tariff, which covers new generation interconnections on SPP's transmission system.

## **Phases of Interconnection Service**

It is not expected that interconnection service will require phases however, interconnection service will not be available until all interconnection facilities and network upgrades can be placed in service.

## **Interconnection Customer Interconnection Facilities**

The Interconnection Customer will be responsible for all of the transmission facilities connecting the customer owned substation to the Point of Interconnection (POI), at a new Oklahoma Gas and Electric owned 345kV bus which will tap and tie in the planned Woodward – Thistle 345kV double circuit. GEN-2012-016 will build a new 345/138kV transformer along with approximately six (6) miles of 345kV transmission line to tie into Western Farmers Electric Cooperative owned Mooreland Substation that will be expanded to include a 345kV switch yard. The Interconnection Customer will also be responsible for any equipment located at the Customer substation necessary to maintain a power factor of 0.95 lagging to 0.95 leading at the POI.

## **Transmission Owner Interconnection Facilities and Non-Shared Network Upgrades**

To allow interconnection Oklahoma Gas and Electric (OKGE) will need to construct a new substation with five 345kV breakers for rerouting of the planned Woodward – Thistle double circuits along with relaying, and any associated terminal equipment for acceptance of the Interconnection Customer's Interconnection Facilities. Western Farmers Electric Cooperative (WFEC) will need to expand the Mooreland Substation to include 345kV switching and construction of a new 345/138/13kV transformer. Western Farmers Electric Cooperative (WFEC) will also construct six (6) miles of 345kV will interconnect the Mooreland Substation to the new substation. At this time GEN-2012-016 is responsible for \$32,312,894.00 of Transmission Owner Interconnection Facilities and Non-Shared Network Upgrades.

## **Shared Network Upgrades**

The Interconnection Customer was studied within the DISIS-2012-002 Impact Study. At this time, the Interconnection Customer is allocated \$0.00 for Shared Network Upgrades. If higher or equally queued interconnection customers withdraw from the queue, suspend or terminate their GIA, restudies will have to be conducted to determine the Interconnection Customers' allocation of Shared Network Upgrades. All studies have been conducted on the basis of higher queued interconnection requests and the upgrades associated with those higher queued interconnection requests being placed in service. At this time, the Interconnection Customer is allocated the following cost for Shared Network Upgrade:

Share Network Upgrade Description	Allocated Cost	Total Cost
None	\$0.00	\$0.00
Total	\$0.00	

**Previous Network Upgrades**

Certain Other Network Upgrades are currently not the cost responsibility of the Customer but will be required for full Interconnection Service. These Other Network Upgrades include:

1. Matthewson – Tap and Tie on Tatonga – Northwest 345kV circuit #1 and Cimarron – Woodring 345kV circuit #1, assigned to DISIS-2011-001 Customers
2. Tatonga – Matthewson – Cimarron 345kV circuit #2, assigned to DISIS-2011-001 Customers
3. Spearville – Mullergren – Reno 345kV double circuit, assigned to DISIS-2011-001 Customers
4. Woodward – Thistle 345kV double circuit, scheduled for 12/31/2014 in-service
5. Thistle – Wichita 345kV double circuit, scheduled for 12/31/2014 in-service
6. Thistle – Flat Ridge 138kV circuit #1, scheduled for 12/31/2014 in-service
7. Thistle 345/138kV transformer circuit #1, scheduled for 12/31/2014 in-service

Depending upon the status of higher or equally queued customers, the Interconnection Customer’s in-service date is at risk of being delayed or their Interconnection Service is at risk of being reduced until the in-service date of these Other Network Upgrades.

**Conclusion**

The Interconnection Customer is responsible for \$32,312,894.00 of Transmission Owner Interconnection Facilities and Non-Shared Network Upgrades. At this time, the Interconnection Customer is allocated \$0.00 for Shared Network Upgrades. At this time, the total allocation of costs assigned to GEN-2012-016 for Interconnection Service is estimated at \$32,312,894.00.



## **FACILITY STUDY**

**for**

### **Generation Interconnection Request 2012-016**

Generating Facility  
Mooreland Oklahoma

June 17, 2013

Steve M. Hardebeck, PE  
Lead Engineer  
Transmission Planning  
**OG&E Electric Services**

## **Summary**

Pursuant to the tariff and at the request of the Southwest Power Pool (SPP), Oklahoma Gas and Electric (OG&E) performed the following Facility Study to satisfy the Facility Study Agreement executed by the requesting customer for SPP Generation Interconnection request Gen-2012-016. The request for interconnection was placed with SPP in accordance SPP's Open Access Transmission Tariff, which covers new generation interconnections on SPP's transmission system. This does not include any relay change out or settings necessary at the Westar Thistle substation. The interconnection customer should contact Westar to determine these costs. The requirements for interconnection consist of building a new substation with five new 345kV breakers, five terminals, resetting relays at Woodward District EHV substation, and routing the existing 345kV Woodward District EHV to Thistle double circuit transmission line into and out of the new substation. The total cost for OKGE to build the new substation with five new 345kV breakers and terminals at a new EHV substation site to be purchased by OG&E, the interconnection facility, is estimated at \$16,844,894.

## Table of Contents

Table of Contents	3
Introduction	4
Interconnection Facilities	5
Interconnection Costs	6
One-Line diagram of Interconnection	7

## **Introduction**

The Southwest Power Pool has requested a Facility Study for the purpose of interconnecting a new generating facility within the service territory of OG&E Electric Services (OKGE) in Woodward County Oklahoma. The proposed 345kV point of interconnection is at a new EHV Substation in Woodward County. This substation will be owned by OKGE.

The cost for adding a new 345kV terminal to a new EHV Substation, the required interconnection facility, is estimated at \$1,099,958. Other Network Constraints in the American Electric Power West (AEPW), OKGE, Western Resources (Westar) and Western Farmers Electric Cooperative (WFEC) systems may be verified with a transmission service request and associated studies.



## **Interconnection Facilities**

The primary objective of this study is to identify attachment facilities. The requirements for the interconnection consist of adding a new 345kV terminal in a new EHV Substation. This 345kV addition shall be constructed and maintained by OKGE. OG&E is proposing to terminate both circuits of the double circuit Woodward EHV to Thistle 345kV transmission line into and out of the new substation. It may be possible to terminate only one circuit pending an imbalance/stability study. The Interconnection customer will be responsible for funding the study. The Customer did not propose a route of its 345kV line to serve its 345kV facilities. It is assumed that obtaining all necessary right-of-way for the line into the new OKGE 345kV substation facilities will not be a significant expense.

The total cost for OKGE to add a new 345kV terminal in a new EHV Substation, the interconnection facility, is estimated at \$1,099,958. This cost does not include building 345kV line from the Customer substation into the new EHV Substation. The Customer is responsible for this 345kV line up to the point of interconnection. This cost does not include the Customer's 345-18kV step up substation costs and those cost estimates should be determined by the Customer.

This Facility Study does not guarantee the availability of transmission service necessary to deliver the additional generation to any specific point inside or outside the Southwest Power Pool (SPP) transmission system. The transmission network facilities may not be adequate to deliver the additional generation output to the transmission system. If the customer requests firm transmission service under the SPP Open Access Transmission Tariff at a future date, Network Upgrades or other new construction may be required to provide the service requested under the SPP OATT.

The costs of interconnecting the facility to the OKGE transmission system are listed in Table 1.

### Short Circuit Fault Duty Evaluation

It is standard practice for OG&E to recommend replacing a circuit breaker when the current through the breaker for a fault exceeds 100% of its interrupting rating with re-closer de-rating applied, as determined by the ANSI/IEEE C37.5-1979, C37.010-1979 & C37.04-1979 breaker rating methods.

For this generator interconnection, no breakers were found to exceed their interrupting capability after the addition of the Customer's generation and related facilities. OG&E found no breakers that exceeded their interrupting capabilities on their system. Therefore, there is no short circuit upgrade costs associated with the Gen-2012-016 interconnection.

**Table 1: Required Interconnection Network Upgrade Facilities**

Facility	ESTIMATED COST (2013 DOLLARS)
OKGE – <b>Interconnection Facilities</b> - Reroute existing double circuit 345kV transmission line into and out of substation	<b>\$1,892,000</b>
OKGE – <b>Interconnection Facilities</b> - Add a new 345kV line terminal to a new EHV Substation. Dead end structures, line switches, line relaying, and revenue metering including CTs and PTs	<b>\$1,099,958</b>
OKGE – <b>Network Upgrades</b> at a new EHV sub, 5-5000A 345kV breakers, 4 line terminals, line relaying, disconnect switches, and associated equipment, reset relays at Woodward District EHV, route existing double circuit 345kV line into and out of substation	<b>\$13,852,936</b>
OKGE - Right-of-Way for 345kV terminal addition	No Additional ROW
<b>Total</b>	<b>\$16,844,894</b>

Prepared by Steve M. Hardebeck, PE

June 17, 2013

Lead Engineer, Transmission Planning  
OG&E Electric Services

Reviewed by: *Travis D. Hyde - P.E.*

# New Woodward District EHV to Western Resources Thistle 345kV Switching Station

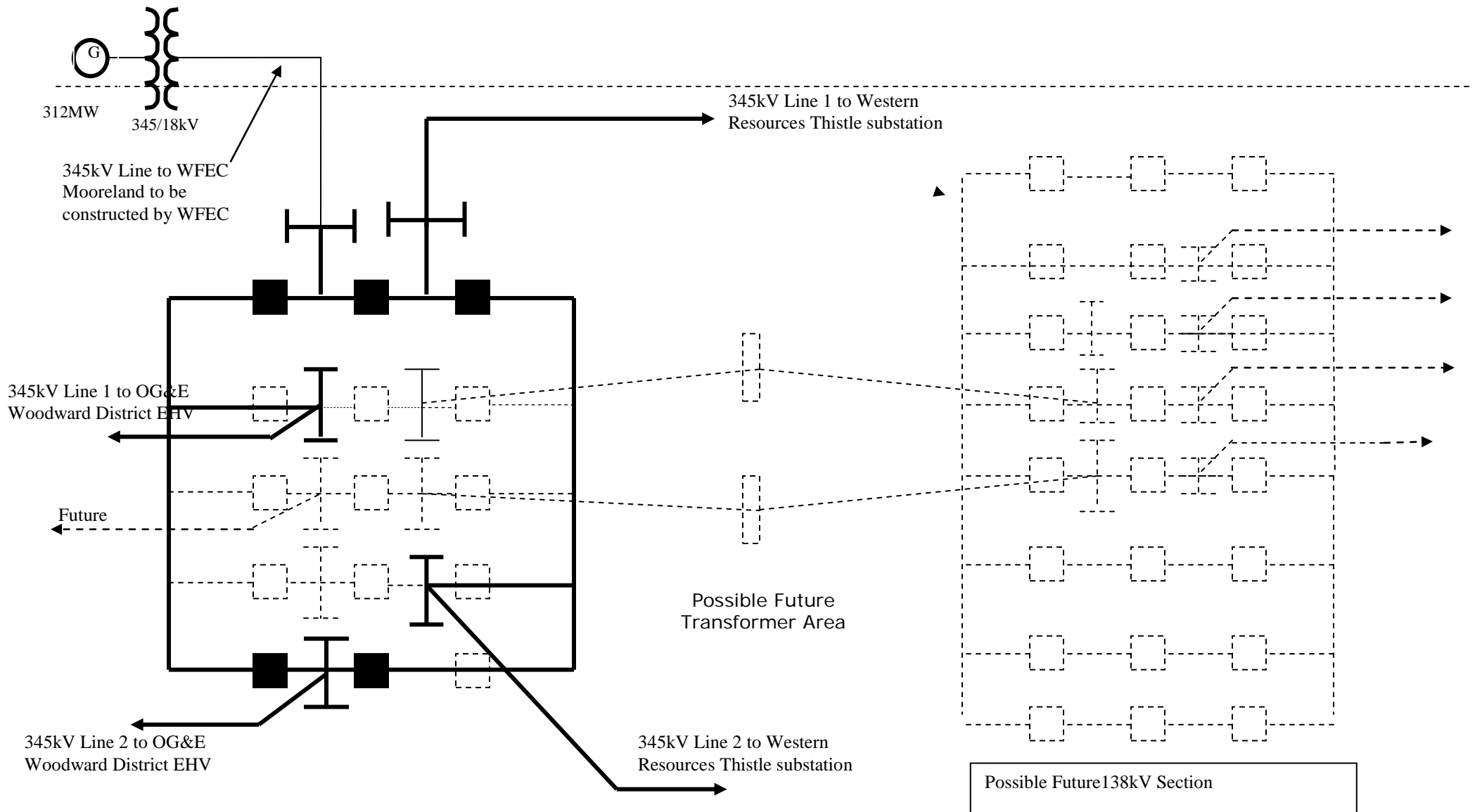

PL

## **Summary**

Western Farmers Electric Cooperative performed the Generation request Gen-2012-016 at the request of SPP (Southwest Power Pool). The request for interconnection was placed with SPP in accordance with SPP's open Access Transmission Tariff, which cover new generation interconnections on SPP's transmission system.

Pursuant to the tariff, Western Farmers Electric Cooperative has performed this generation interconnect facility study to satisfy the agreement executed between the customer and SPP.

## **Customer Interconnection Facilities**

It is assumed that the interconnection point to WFEC will be at the Mooreland 345 kV switchyard. A new 345/138 kV switchyard will be built at the existing WFEC Mooreland Power-Plant. Also, approximately 6 miles of 345 kV transmission line will be built from the new Mooreland 345 switchyard to an OG&E owned 345 kV switchyard site to be determined at a later date.

# ***WESTERN FARMERS ELECTRIC COOPERATIVE***

## FACILITY STUDY

For

Generation Interconnection Request 2012-016

312 MW Combined Cycle Generation Facility

In Woodward County

Near

Mooreland, OK

August 15, 2013

## SUMMARY

Pursuant to the tariff and at the request of the Southwest Power Pool (SPP), Western Farmers Electric Cooperative (WFEC) performed the following facility Study to satisfy the Facility Study agreement executed by the requesting customer for SPP Generation Interconnection request Gen 2012-016. The request for interconnection was placed with SPP in accordance with SPP's Open Access Transmission Tariff, which covers new generation interconnections on SPP's transmission system. The requirements for interconnection consist of building a new 345/138 kV switching station at the Mooreland Powerplant. The switchyard shall be a breaker-and-half arrangement. The switchyard will need to accommodate one circuit for each generator plus a 345/138 kV Auto-transformer to connect to the existing WFEC Mooreland Switchyard and one circuit to connect to OG&E for a total of 4 circuits. Also, approximately 6 miles of 345 kV transmission line will be built from the new Mooreland 345 switchyard to an OG&E owned 345kV switchyard to be determined at a later date.

## INTRODUCTION

The Southwest Power Pool has requested a facility Study for the purpose of interconnecting approximately 312 MW's of generation within the service territory of WFEC in Mooreland, Oklahoma. The interconnect station will be owned by WFEC. The proposed in-service date is approximately March 2017.

Power Flow analysis has indicated that for the power flow case studied, it is possible to interconnect the 312 MW's of generation with transmission reinforcements within the local transmission system. Given the point of interconnection there are additional requirements for interconnection including a new 345/138 kV Switching Station and approximately 6 miles of 345 kV transmission. Also approximately 0.5 miles of 138 kV transmission line will be needed to connect to the existing 138 kV switching station owned by WFEC. The existing 138 kV switching station owned by WFEC will also require a new 138 kV bay and associated equipment.

See Table 1 for estimated costs for construction:

## **INTERCONNECTION & TRANSMISSION FACILITIES**

The requirements for interconnection consist of building a new 345/138 kV switching station and other line and equipment mentioned above. WFEC will be responsible for acquiring the necessary right-of-way for the 345 kV interconnect transmission line to OG&E.

The total cost for WFEC for this interconnection is estimated at \$15,468,000.

This facility study does not guarantee the availability of transmission service necessary to deliver additional generation to any specific point inside or outside of the SPP transmission system. The transmission network may not be adequate to deliver any additional generation output to the system. If the customer requests firm transmission service under the SPP open access transmission tariff at a future date, network upgrades or other new construction may be required to provide the service.

The costs of interconnecting to WFEC's facilities are listed in Table 1 below.



Facility	Estimated Cost (2013 Dollars)
A new 345/138 kV breaker-and-half switching station at the Mooreland Powerplant.	\$8,250,000
Approximately 6 miles of 345 kV transmission line. It is assumed that OG&E has included the cost of interconnection equipment in their station.	\$6,000,000
Approximately 0.5 miles of 138 kV transmission line to connect to the existing 138 kV switching station owned by WFEC	\$468,000
New 138 kV bay and associated equipment	\$750,000
<b>Total</b>	<b>\$15,468,000</b>

Table 1